

Comparative evaluation of shear bond strength of a dual-cure core build-up composite bonded to dentin using three different self-etch dentin bonding systems - An in-vitro study

Gaurav Jain^{1,*}, Balakrishnan Rajkumar², Lalit C. Boruah³, R. S. Bedi⁴

¹Associate Professor, ^{2,4}Principal, Professor and HOD, ³Professor, ^{1,3}Dept. of Conservative Dentistry and Endodontics, ⁴Dept. of Oral and Maxillofacial Surgery, ^{1,4}Saraswati Dental College, Lucknow, Uttar Pradesh, ^{2,3}BBD College of Dental Sciences, Lucknow, Uttar Pradesh, India

***Corresponding Author:**

Email: gauravjs23@yahoo.com

Abstract

Aim: This *in-vitro* study compared the shear bond strength of a dual-cure core build-up composite bonded to dentin using a two-step self-etch adhesive, with two, single step self-etch universal adhesive systems.

Materials and Methods: In the present *in-vitro* study, sixty extracted permanent human mandibular molar teeth, decoronated below the dentino-enamel junction to expose the coronal dentin, were taken and later mounted in self-cure acrylic resin. The specimens were randomly divided into three groups of twenty samples each, based on the dentin bonding agents used namely ParaBond (a two-step self-etch adhesive) and two one-step universal adhesives i.e. Single Bond Universal and Tetric N-Bond Universal. The dentin surface of samples was treated with the respective adhesives of the groups according to manufacturer's instructions. The bonded surface was bulk filled using ParaCore dual-cure composite. The attained samples were stored in distilled water at 37°C for 24hrs and subsequently put through thermocycling (5°C to 55°C for 500 cycles). The samples were then subjected to shear loading in Instron Universal testing machine. The data were tabulated and statistically analyzed using analysis of variance (ANOVA) and Tukey's HSD test.

Results: Tetric N-Bond Universal adhesive showed the highest mean Shear Bond Strength (SBS) of 20.78 MPa, followed by Single Bond Universal 19.07 MPa and ParaBond Adhesive 5.44 MPa.

Conclusion: Tetric N-Bond Universal showed the highest mean SBS and a predictable relationship was found between the formulation of dentin adhesive systems and their shear bond strength values.

Clinical Significance: The universal adhesives showed high shear bond strength as compared to conventional 2-step self-etch adhesives. High acidic pH of self-etch adhesive affected their bond strength. So for stake of bond stability, a mild self-etch / universal adhesive is recommended for adhesion, because higher the bond strength, higher it can withstand the stress resulting in a successful restoration.

Keywords: Adhesives, Dentin, Dual-cure composite resins, Shear bond strength.

Introduction

Traditionally, materials like silver amalgam, hybrid and resin modified glass ionomer, cast metal alloys and resin-based composites have been used as core restoration materials for an extensively carious, severely damaged, fractured or endodontically treated teeth. But large percentage of their failure to resist intraoral compressive, tensile and shear occlusal forces, led to development of various dual-cured composites. ParaCore (Coltene Whaledent) is one such fiber-reinforced dual-cure core build-up composite introduced recently, incorporating glass particles that impart, high strength and flexibility similar to that of dentin.^{1,2} But an important factor affecting the intra-oral performance of these dual-cure composite resin restorations is adhesion and dental adhesives are an integral part of these system that promote adhesion between dental substrate and dual-cure composite.³

Adhesive technology has evolved rapidly since it was introduced, as bonding to enamel was proven to be durable rather than to dentin which was considered more intricate.⁴ This is partly due to biological characteristic of dentin which is a dynamic tissue composed of hypermineralized collagen matrix filled

with apatite crystals, dentinal tubules, peritubular dentin and the presence of dentin smear layer formed immediately after cavity preparation.^{5,6}

Dentin adhesive systems can be classified into two main categories according to different bonding techniques to the dental substrate: the etch-and-rinse and self-etch systems.⁴ Different from etch-and-rinse adhesives, self-etch adhesives do not require a separate etching step, as they contain acidic monomers that simultaneously act as conditioner (that allow dentin demineralization) and primer agents (resin monomers that infiltrates into dentin) upon the dental substrates.⁷

Self-etch adhesives are classified according to their initial pH value, depending on their composition and concentration of polymerizable acids and/or acid resin monomers: 'mild' (pH >2), 'moderate/intermediately strong' (pH between 1 and 2) and 'strong' (pH ≤1). They come as 'two step' and 'one step' adhesives, depending on whether a self-etching primer and adhesive resin with organic solvent are separately provided or combined into a single solution. These can be further subdivided into 'two-component' (separating 'active' ingredients like functional monomer from

water) and 'single-component' (combine primer, functional monomer and organic solvent) adhesives.⁴

One step single-component adhesive are considered as 'all-in-one' adhesives, but the challenge to provide equally effective bond to dental substrates of different nature led to the development of new family of adhesives known as 'universal' that gave an opportunity to decide on which adhesive strategy to use: etch-and-rinse or self etch. These are designed under the true 'all-in-one' concept, incorporating the versatility of being adaptable to clinical situations and providing stable and durable bond.^{8,9}

Hence the aim of this study was to evaluate the Shear Bond Strength (SBS) produced by these new commercially available one-step universal bonding agents namely Single Bond Universal (3M ESPE) and Tetric N-Bond Universal (Ivoclar Vivadent) with a two-step self-etch ParaBond (Coltene Whaledent) using a dual-cure ParaCore (Coltene Whaledent) core build-up composite.

Materials and Methods

The materials used in the study were a dual-cure composite ParaCore with three adhesive systems namely ParaBond, Single Bond Universal and Tetric N-Bond adhesive systems. [Table 1]

Specimen Preparation: In the present *in-vitro* study, sixty extracted permanent human mandibular molar teeth, caries free, non-carious lesion free with normal anatomical form and structure were chosen, cleaned with ultrasonic scaler (Biosonic, Coltene Whaledent, USA) and stored in distilled water at room temperature, the preferred method of storage with least negative influence on the measured bond strength as suggested by Titely Kc et al.¹⁰ and Numann M et al.¹¹ The teeth were decoronated using a carborandum disc (Dentsply, USA) beneath the dentino-enamel junction to expose the coronal dentin surface and later finished with 600-grit silicon carbide paper (John Oakey & Mohan Ltd., India) to produce a uniform smear layer. The remaining apical part of each tooth up to 1mm from cemento-enamel junction was mounted in auto-polymerizing pink orthodontic resin (Pyrex, India) using custom made cylindrical stainless steel moulds (size 18mm height and 12mm diameter).

The teeth were than randomly assigned to three groups on the basis of adhesive systems used (Group A- ParaBond, Group B- Single Bond Universal, Group C- Tetric N-Bond Universal), each group consisting of twenty samples. The specifications of all adhesive systems are listed in Table 1.

Dentin Treatment: Group A: The dentin surface was treated with ParaBond Non-Rinse Conditioner, scrub for 30 seconds, air dry for 2 seconds, followed by application of pre-mixed Adhesive A and Adhesive B on conditioned dentin surface for 30 seconds, air drying

for 2 seconds and left for self-curing for 2min before core build-up.

Group B: The dentin surface was treated using Single Bond Universal dental adhesive, with gentle agitation and air thinned for 5 seconds, followed by light curing for 10 seconds using light curing unit (550mW/cm²) (Coltolux 2.5 Coltene, Switzerland).

Group C: The prepared dentin surface was treated using Tetric N-Bond Universal dental adhesive, with gentle agitation and air thinned for 5 seconds, followed by light curing for 10 seconds using light curing unit (550mW/cm²).

Dual-cure composite build-up: For all groups, ParaCore dual-cure core build-up composite was bulk filled on the treated dentin surface using polyvinyl moulds (coated with non-reactant petroleum jelly on inner walls) of dimensions 5mm internal diameter and 5mm height at room temperature. These were then initially light cured for 20 seconds per surface to initiate polymerization and to achieve final set, left for 4 min for auto-polymerization as a standard for all groups. The polyvinyl moulds were later dismantled to yield samples.

The attained samples were stored in distilled water at 37°C for next 24 hrs and subsequently put through thermocycling (5°C to 55°C for 500 cycles with a corresponding dwell time of 30 seconds and 10 seconds transit time between baths according to ISO #11405 standard).¹²⁻¹⁴

Finally, the samples were subjected to SBS test using Instron Universal Testing Machine (Model 3382, Instron Industries, USA), following the 2003 ISO Technical Specification #11405,¹³ at a cross-head speed of 0.5mm/min until the specimens fractured under shear load. Shear force was applied perpendicular to the tooth surface by means of a custom steel rod, to evaluate the bond strength of the adhesive systems studied. The maximum load necessary to de-bond was recorded in Newton (N) and calculated in MPa as a ratio of Newton to surface area of bulk filled composite. [Fig. 1]

The data were tabulated and statistically analyzed using analysis of variance (ANOVA) and Tukey's HSD test to determine whether significant differences in de-bond strength values existed between groups. The selected level of significance was set at a p value<0.05. Analysis was performed on SPSS 19 software (IBM Corporation, Chicago).

Table 1: Materials used in this study

Materials	Manufacturer	Composition	pH
ParaCore	Coltene Whaledent, USA	UDMA, Trimethylolpropane Trimethacrylates (TMPTMA), Bis-GMA, TEGDMA, di-benzoyl peroxide, Sodium fluoride, Barium glass, Amorphous Silica	ND
ParaBond Non-Rinse Conditioner		2-hydroxyethyl methacrylate (HEMA), Acrylamidosulfonic acid, Water	0.9 - 1.3
ParaBond Adhesive A		HEMA, GDMA, Maleic acid, di-benzoyl peroxide, Ethanol	
ParaBond Adhesive B		Ethanol, Water, Initiators	
SingleBond Universal	3M ESPE, St. Paul, MN, USA	MDP Phosphate monomer, Dimethacrylate resins, HEMA, Vitrebond Copolymer, Filler, Ethanol, Water, Initiators, Silane	2.7
Tetric N-Bond Universal	Ivoclar-Vivadent, Schaan, Liechtenstein	Bis-acrylamide deriviate, Bis-methacrylamide dihydrogenphosphate, Amino acid acrylamide, Hydroxyalkyl methacrylamide, SiO ₂ , Water	2.5 - 3.0

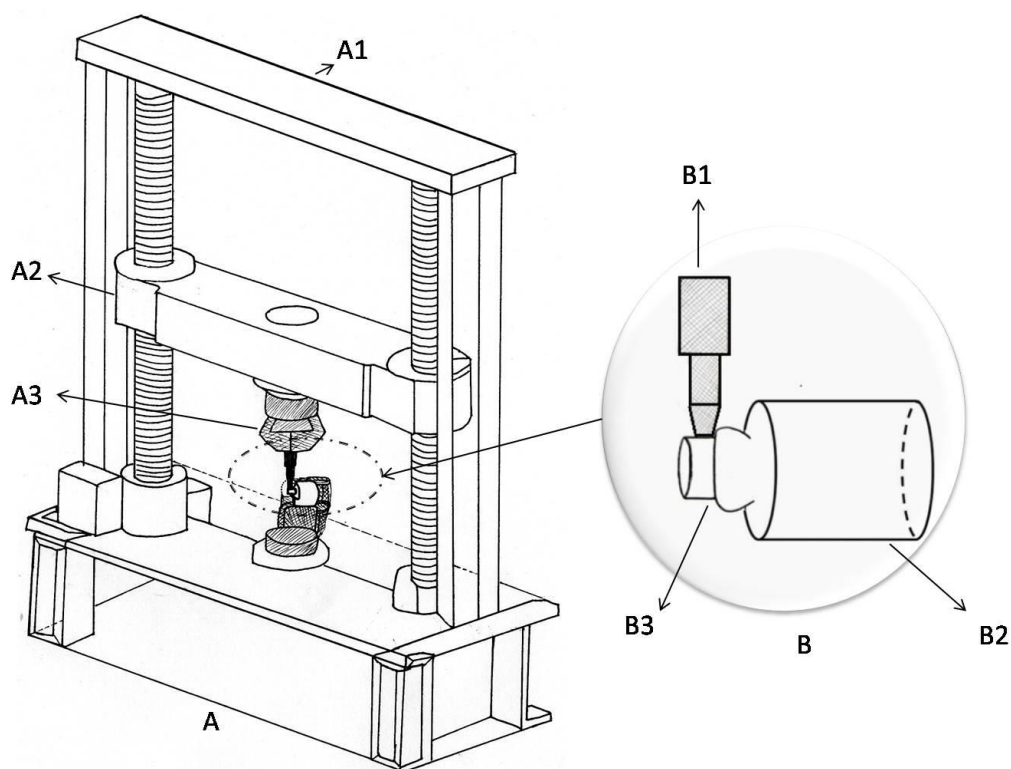

Fig. 1: Schematic diagram of shear load assembly for shear bond strength test. (A): Shear load testing in Instron Universal testing machine. (A1): Fixed cross head. (A2): Movable cross head. (A3): Manual non-shift wedge type grips to hold custom rod for load application. (B)- Bonded assembly for shear strength testing. (B1): Custom rod for load application. (B2)- Auto-polymerizing resin mould with mounted tooth. (B3): Tooth bonded specimen ready to engage beneath testing machine rod

Results

The mean SBS (MPa) and descriptive statistics are presented in Table 2 and Table 3 respectively. ANOVA showed a significant difference in mean SBS between three groups ($p < 0.05$). Group C showed the highest

mean SBS of 20.78 MPa, Group B showed mean SBS of 19.07 MPa, while Group A showed the least mean SBS of 5.44 MPa. Between-group comparison showed

a statistically significant effect of groups ($f = 16875.79$, $p < 0.001$).

Table 2: Shear bond strength (Mean \pm SD) of three groups using ANOVA

Groups	N	Mean	Std. Deviation	Std. Error Mean
Group A	20	5.44	0.4512	0.1009
Group B	20	19.07	0.1044	0.0233
Group C	20	20.78	0.1918	0.0429

SD: Standard deviation

Table 3: Significance (p values) of mean difference of SBS between the groups by Tukey's HSD test

Comparisons	p - value	Tukey HSD Q statistic
Group A vs. Group B	0.001	210.6115
Group A vs. Group C	0.001	237.0611
Group B vs. Group C	0.001	26.4495

SBS: Shear bond strength, HSD: Honestly significant difference, Q: Quantile

Discussion

Adhesive bonding in dentistry is a process dependent on several factors, such as the type and humidity of dental substrate, type of adhesive system used and operator's ability in performing bonding procedure. Bonding to dentin is challenging due to its dynamic nature, structure (constituted of both mineral and organic phases) and being a wet substrate, requiring the application of both hydrophilic and hydrophobic material preventing collagen matrix collapse and subsequent adhesive infiltration into demineralized substrate.¹⁵

In-vitro bond strength tests are useful and essential for predicting the performance of adhesive systems and their possible correlation with clinical issues.¹⁶ An accepted principal states that a successful adhesive bonding depends on the chemistry of adhesive and morphological changes caused by them on dental tissue, forming a continuous transition between the restorative material and dental substrate, thereby increasing the survival possibility.^{17,18} So the rationale behind the present *in-vitro* study was that, higher the actual bonding capacity of an adhesive, the better it will withstand such stresses and longer the restoration will survive *in-vivo*.

Bond strength tests are capable of ranking dental adhesive systems according to their bond strength values. However, some factors like masticatory stresses, temperature and wet environment, must be taken into consideration, that could influence the bond strength in clinical situations and might lead to rapid degradation of the adhesive interface.¹⁹⁻²³ So, to ensure the validity of present SBS test, bond strength evaluation was performed *in-vitro*, 24hrs after specimen preparation with storage in distilled water at 37°C and thermocycling (5°C to 55°C for 500 cycles with a corresponding dwell time of 30 seconds and 10 seconds transit time between baths according to ISO #11405 standard). According to literature, 24hrs is considered an adequate time to test the adhesive capability of the

material and thermocycling is an artificial aging methodology that simulate stresses caused by oral functions and subjects the specimens to altering temperatures that induce contraction and expansion stress between the adhesive and tooth due to differences in the coefficient of thermal expansion,^{1,21} to predict the clinical performance of dental adhesive systems studied.

The mean (\pm SD) SBS of Group A was found to be least as compared with Group B and Group C. This variation among bond strength values of the adhesive systems may be related to their different pH values (acidity), different functional monomers, water and or other organic solvent concentration and filler content.

Adhesive in Group A is strong acidic due to presence of acrylamidosulfonic acid and maleic acid (pH= 0.9-1.3) as compared to Group B and Group C which are mild acidic (pH= 2.5-3). Previous studies have shown that strong self-etch adhesives containing molecules like maleic acid, decalcifies hydroxyapatite (HAp), thus have demineralizing effect on dentin, just as etch-and-rinse adhesive systems do.²⁴ However this fact did not translate into higher bond strengths, as the dissolved calcium phosphates are not rinsed and these embedded calcium phosphates are very unstable in aqueous environment. So functional monomer in Group A, 2-hydroxyethyl methacrylate (HEMA) will initially bond to calcium (Ca) of HAp but will readily de-bond, leading to a relatively deep 3-5 μ m hybrid layer at dentin that does no longer contain HAp crystals, thereby debilitating the integrity of adhesive interface with the exposed dentin and collagen.⁴

On the contrary, mild self-etch adhesives having MDP (methacryloyloxydecyl dihydrogen phosphate) superficially interact with dentin and hardly dissolve HAp crystals, leaving their substantial amount around collagen fibrils.^{4,25} So, MDP found in Group B and Group C adhesive systems, interacts with surface dentin producing a reaction-integration layer, with a depth of about 300nm-1 μ m, and chemically bond to Ca of HAp,

forming stable calcium-phosphate and calcium-carboxylate salts.^{14,26} Thus simultaneous demineralization and infiltration of dentinal surface forms a stable resin-infiltrated dentin hybridization layer,^{25,27} and the combination of this micromechanical interlocking and chemical adhesion is probably responsible for high SBS.

Moreover, studies show that HEMA, functional monomer in Group A, has low hydrolytic stability in strong acidic adhesives because the ester portion of the molecule could be hydrolyzed in aqueous solutions when pH values are around 1. While mild acidic adhesive systems of Group B and C having MDP monomer, because of its long linear alky/carbonyl chain, maintain an acceptable hydrolytic stability in acidic solutions despite of the ester portion of the molecule. This helps to create a balance between the advantages and disadvantages of the influence of pH values.^{7,26}

Most self-etch adhesives are formulated to be hydrophilic and water is an essential component in formulation for ionizing the acidic monomer to dissolve the smear layer and demineralize the dentin.²⁸ Pashley et al.²⁹ and Tay et al.³⁰ showed that incorporation of high concentration of acidic monomer HEMA, decreases the vapor pressure of water, leading to water sorption from host dentin. This excess water entrapped in adhesive resin forms water blisters ('over-wet phenomenon') which act as weak spot along the adhesive interface. So, high amounts of HEMA in the adhesive composition, results in flexible polymers with inferior quality and reduced bond strength.³¹ This phenomenon could also be a possible explanation of lowest mean SBS obtained by ParaBond self-etch adhesive of Group A.

Further, the highest mean SBS of Group C as compared to Group B can be attributed to the difference in their monomer and copolymer content. Tetric N-Bond Universal is based on a combination of methacrylated carboxylic acid polymer (MCAP) and hydrophilic monomers like MDP, HEMA, hydrophobic monomer Decandiol dimethacrylate (D3MA) and intermediate monomer Bisphenol A glycidyl methacrylate (Bis-GMA). Studies show that this combination of properties allows Tetric N-Bond Universal to reliably bridge the gap between the hydrophilic dentin substrate and hydrophobic resin restorative under variety of surface conditions imparting high mean SBS.³ Whereas, Single Bond Universal is based on combination of Vitrebond Copolymer (polyalkenoic acid copolymer) in combination with hydrophilic monomers MDP, HEMA and dimethacrylate resin. Although MDP is a recognized monomer able to chemically interact with Ca of HAp and micromechanically bond to dentin. But contrary to manufactures assert on Vitrebond Copolymer that it enhances wetting of MDP monomer on dentin surface, literatures state that this polyalkenoic

acid copolymer compete with MDP monomer for Ca-bonding sites in HAp rather than aiding its adhesion and could even prevent monomer approximation during polymerization.³

Additionally, the high mean shear bond strength of Group B and Group C as compared to Group A can also be ascribed to the presence of nano-fillers silicone dioxide (SiO₂) (approx. 5 wt%) in adhesive used, while Group A adhesive lack the nano fillers. As filler ensures high density promoting filling of microporosities created on dentin, elevating the mechanical adhesion.³² Studies by Miyazaki et al.³³ also reported higher filled adhesives yield stronger physical properties because of their ability to flex and relieve polymerization stress.

Universal adhesives of Group B and C showed significantly higher SBS and surprisingly, the core build-up composite manufacturer's two-step self etch adhesive of Group A had very low SBS. However, dentin adhesive systems tested in the present study were known to be relatively equivalent to each other in dentin bond strengths, so the variations found in bond strength were thought to be extremely dentin adhesive formulation dependent.

Limitations and Future scope

In the present study, though the compositions of the adhesive systems are different in functional monomers, pH values and filler content, but being *in-vitro* test, bond strength to dentin has following inherent limitations such as type and age of teeth used, degree of dentin demineralization, type of bond strength test, storage media and environmental surface humidity. Despite these limitations with this research, 'universal adhesives' have shown promising and satisfactory SBS under simulated clinical conditions, which support their use as bonding agents for dual-cure core build-up composites.

Conclusion

Based on the findings of the present *in-vitro* study, we can conclude 'Universal Adhesives' yield high SBS when compared with two-step self etch adhesive for dual-cure core build-up composite. The chemical and micro-mechanical bonding provided by MDP, functional monomer of universal adhesive and high filler content resulted in high SBS values. Additionally, the content of acidic monomer could affect the bond strength, so for stake of bond stability, a mild self-etch / universal adhesive is recommended for adhesion.

Conflicts of Interest: Nil

References

1. Jain G, Narad A, Boruah LC, Rajkumar B. Comparative evaluation of shear bond strength of three resin based dual-cure core build-up materials: an In-vitro study. *J Conserv Dent* 2015;18(4):337-41.
2. Agarwal A, Mala K. An *in vitro* comparative evaluation of physical properties of four different types of core materials. *J Conserv Dent* 2014;17(3):230-33.

3. Jayasheel A, Niranjana N, Pamidi H, Suryakanth MB. Comparative evaluation of shear bond strength of universal dental adhesives - an *in vitro* study. *J Clin Exp Dent* 2017;9(7):e892-96.
4. Van Meerbeek B, Yoshikawa K, Mine A, De Munck J, Van Landuyt KL. State of the art of self-etch adhesives. *Dent Mater* 2011;27(1):17-28.
5. Pegado RE, do Amaral FL, Florio FM, Basting RT. Effect of different bonding strategies on adhesion to deep and superficial permanent dentin. *Eur J Dent* 2010;4(2):10-17.
6. Perdigao J. New developments in dental adhesion. *Dent Clin N Am* 2007;51(2):333-57.
7. Moszner N, Salz U, Zimmermann J. Chemical aspects of self-etching enamel dentin adhesives: a systematic review. *Dent Mater* 2005;21(10):895-910.
8. Wagner A, Wendler M, Petschelt A, Belli R, Lohbauer U. Bonding performance of universal adhesives in different etching modes. *J Dent* 2014;42(7):800-807.
9. Costa VF, Campos LM, Ayala MD, Miranda Jr WG, Brandt WC, Roman-Torres CVG et al. Comparison of different adhesive techniques using a universal adhesive system. *Appl Adh Sci* 2017;5(18):1-7
10. Titley KC, Chernecky R, Rossouw PE, Kulkarni GV. The effect of various storage methods and media on shear-bond strengths of dental composite resin to bovine dentine. *Arch Oral Biol* 1998;43(4):305-11.
11. Naumann M, Metzendorf G, Fokkinga W, Watzke R, Sterzenbach G, Bayne S, Rosentritt M. Influence of test parameters on *in vitro* fracture resistance of post-endodontic restoration: a structured review. *J Oral Rehabil* 2009;36(4):299-312
12. Gale MS, Darvell BW. Thermal cycling procedures for laboratory testing of dental restorations. *J Dent* 1999;27(2):89-99.
13. International Organization for Standardization. ISO/TR 11405 Dental Materials-guidance on Testing of Adhesion to Tooth Structure. Geneva, Switzerland: WHO; 1994. p. 1-13.
14. Makishi P, Andre CB, Ayres APA, Martins AL, Giannini M. Effect of storage time on bond strength and nanoleakage expression of universal adhesives bonded to dentin and etched enamel. *Oper Dent* 2016;41(3):305-317
15. Isolan CP, Valente LL, Munchow EA, Basso GR, Pimentel AH, Schwantz JK, V da Silva A, Moraes RR. Bond strength of a universal bonding agent and other contemporary dental adhesives applied on enamel, dentin, composite, and porcelain. *Appl Adh Sci* 2014;2:25
16. Barkmeier WW, Cooley RL. Laboratory evaluation of adhesive systems. *Oper Dent* 1992;Suppl 5:50-61
17. De Munck J, Vargas M, Van Landuyt K, Hikita K, Lambrechts P, Van Meerbeek B. Bonding of an auto-adhesive luting material to enamel and dentin. *Dent Mater* 2004;20(10):963-71
18. Heintze SD. Systematic Reviews: I. The correlation between laboratory test on marginal quality and bond strength. II. The correlation between marginal quality and clinical outcome. *J Adhes Dent* 2007;9(Suppl 1):77-106
19. Drummond JL, Sakaguchi RL, Racean DC, Wozny J, Steinberg AD. Testing mode and surface treatment effects on dentin bonding. *J Biomed Mater Res* 1996;32(4):533-41.
20. Li H, Burrow MF, Tyas MJ. The effect of load cycling on the nanoleakage of dentin bonding systems. *Dent Mater* 2002;18(2):111-19.
21. Nikaido T, Kunzelmann KH, Chen H, Ogata M, Harada N, Yamaguchi S, Cox CF, Hickel R, Tagami J. Evaluation of thermal cycling and mechanical loading on bond strength of a self-etching primer system to dentin. *Dent Mater* 2002;18(3):269-75.
22. Price RB, Derand T, Andreou P, Murphy D. The effect of two configuration factors, time, and thermal cycling on resin to dentin bond strengths. *Biomater* 2003;24(6):1013-21.
23. Loguercio AD, Uceda-Gomez N, Carrilho MR, Reis A. Influence of specimen size and regional variation on long-term resin-dentin bond strength. *Dent Mater* 2005;21(3):224-31.
24. Poggio C, Beltrami R, Scribante A, Colombo M, Chiesa M. Shear bond strength of one-step self-etch adhesives: pH influence. *Dent Res J* 2015;13(3):209-14.
25. Lozada MP, Rayo HG. Self-etching adhesive systems, bond strength and nanofiltration: a review. *Rev Fac Odontol Univ Antioq* 2012;24(1):133-50.
26. Giannini M, Makishi P, Ayres APA, Vermelho PM, Fronza BM, Nikaido T, Tagami J. Self-etch adhesive systems: a literature review. *Braz Dent J* 2015;26(1):3-10.
27. Leite MLAS, Costa CAS, Duarte RM, Andrade AKM, Soares DG. Bond strength and cytotoxicity of a universal adhesive according to the hybridization strategies to dentin. *Braz Dent J* 2018;29(1):68-75.
28. Tay FR, Sano H, Carvalho R, Pashley EL, Pashley DH. An ultrastructural study of the influence of acidity of self-etching primers and smear layer thickness on bonding to intact dentin. *J Adhes Dent* 2000;2(2):83-98.
29. Pashley EL, Zhang Y, Lockwood PE, Rueggeberg FA, Pashley DH. Effects of HEMA on water evaporation from water-HEMA mixtures. *Dent Mater* 1998;14(1):6-10.
30. Tay FR, Gwinnett JA, Wei SH. Relation between water content in acetone/alcohol-based primer and interfacial ultrastructure. *J Dent* 1998;26(2):147-56.
31. Van Landuyt KL, Snauwaert J, De Munk J, Peumans M, Yoshida Y, Poitevin A, Coutinho E, Suzuki K, Lambrechts P, Van Meerbeek B. Systematic review of the chemical composition of contemporary dental adhesives. *Biomater* 2007;28(26):3757-85.
32. Beltrami R, Chiesa M, Scribante A, Allegretti J, Poggio C. Comparison of shear bond strength adhesives on etched and nonetched enamel. *J Appl Biomater Funct Mater* 2016;14(1):78-83.
33. Miyazaki M, Ando S, Hinoura K, Onose H, Moore BK. Influence of filler addition to bonding agents on shear bond strength to bovine dentin. *Dent Mater* 1995;11(4):234-38.

How to cite the article: Jain G, Rajkumar B, Boruah LC, Bedi RS. Comparative evaluation of shear bond strength of a dual-cure core build-up composite bonded to dentin using three different self-etch dentin bonding systems - An in-vitro study. *J Dent Specialities* 2018;6(2):160-165.